

SEED 850 LED

- designed to exceed everyday demands in all applications
- stringent engineering and testing practices
- highest efficiency and durability in the harshest conditions



ABL

OE Approved
Heavy Duty Lighting Product



SHD 850 LED

The SHD 850 LED series work lights are designed to exceed everyday demands in all applications. Through stringent engineering and testing practices, we ensure the highest efficiency and durability in even the harshest operating conditions.

Dimensions

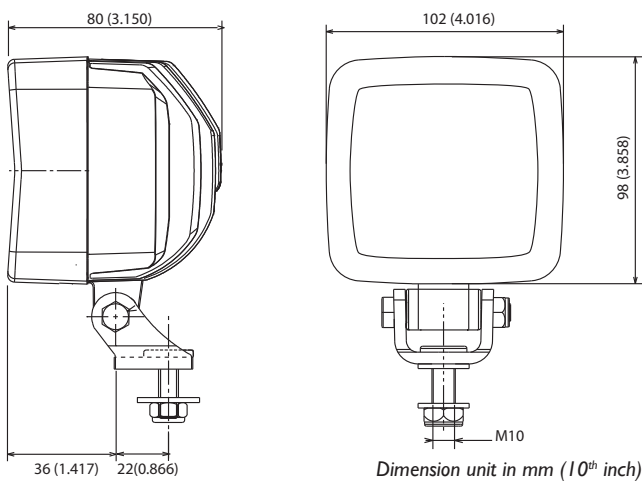

Light Patterns

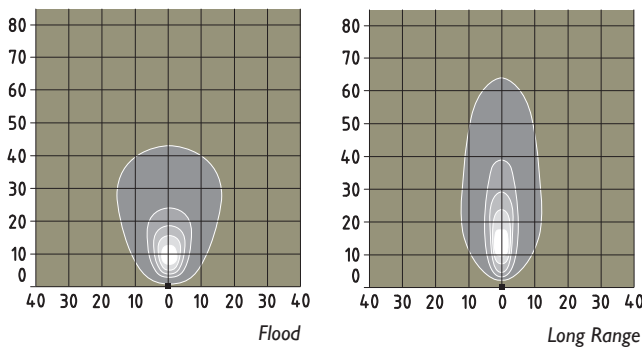

Specifications

Bulb	12 LED - 850 Lumen
Lifetime	20 000 hours
Color temperature	6000°K
Light pattern	Flood, Long Range
Consumption	11 W
Voltage	Multi 12-24V
Intensity	0,46 Amp @ 24Vdc
Weight	0,9 Kg
Vibration resistance	15 Grms from 24 to 2000Hz
Shock resistance	60 G
EMC	ISO 13 766 - ISO 14 982 - ISO 12 895
Load Dump	36V continuous 72V 100 ms 1800 V 50 μs
Polarity	protected against reverse voltage
Electronic Thermal Management	full output @ +35°C ambient 25% dimmed @ +50°C ambient
Water Tightness	IP 68 - IP 69K
Operating Temp	-40°C to +85°C
Salt Spray	ISO 9227
Lens	hardened glass
Reflector	free form reflector
Warranty	20 000 operating hours or 4 years

Connection

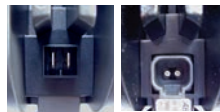

Built-in AMP 2 ways Built-in DT 2 ways

Options

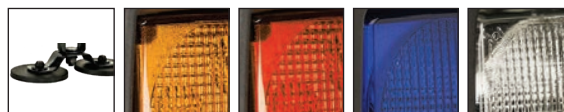

Double Magnetic base Amber plastic Red Plastic Blue Plastic Clear Plastic

Mounting

